

433 MHz



Non-compliance with the specification might cause risk for life or health and can determine proper work of the blind.
We strongly recommend to comply with the specification.

1. General information



LE type motors equipped with a radio receiver are wireless and can be controlled with a remote. They are designed for automation of roller shutters. They have electronic limit switches which are programmed by the remote control. Built-in battery allows motor installation without power supply. LE type motores are compatible with all YOODA transmitters.

Radio receiver memory:
up to 20 transmitters

Power supply:
12 V DC

Operating temperature:
from -5°C to 50°C

Protection degree:
IP 40

Load:
up to 1,5 kg

Illustrations (from the top):

Fig. 1. 18 LE motor with radio receiver (for roller blind in the cassette)

Fig. 2. 18 LE motor with radio receiver (for roller blind free-hanging)

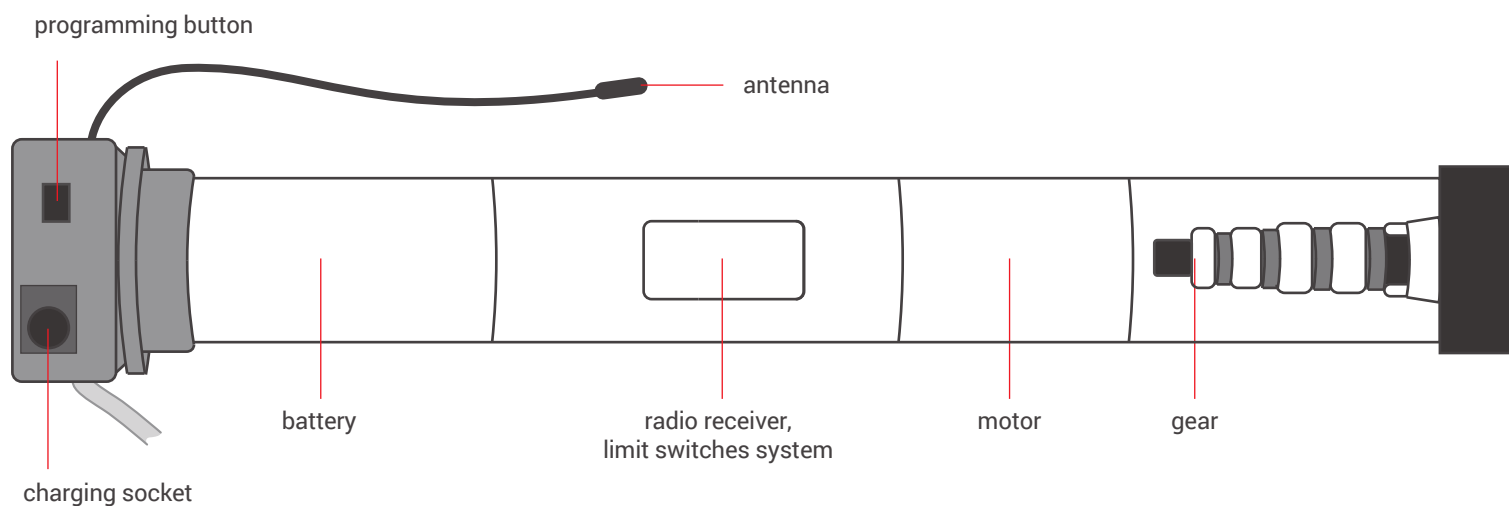

2. Safety measures

Before installing or using motor please read the following instruction. The installer must comply with the standards and regulations in force in the country where the appliance will be installed and provide information to users about the conditions and maintenance of the device. Failure to follow these instructions can present risk to life and health, or invalid functioning of the roller shutter. This also results in the loss of warranty rights.



Motors torque parameter should be adequate to the weight of the roller shutter curtain.



Electrical system control should be performed regularly to detect any signs of use or damage of the motor.



Do not hit the motor. Reduce the vibration of the motor to a minimum.



All contact of the motor with any liquids should be reduced to minimum.



No tools should be used when placing motor in the tube.



Motor and its control system should be kept out or reach of children.



During the adapter montage special attention must be paid not to damage the motor.

3. Placing motor in the tube



Motor should be mounted in places protected from unfavourable weather conditions. Do not pull the motor head when removing it from the tube.

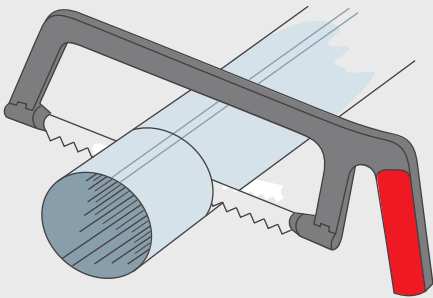

1. Cut the tube to the proper length.

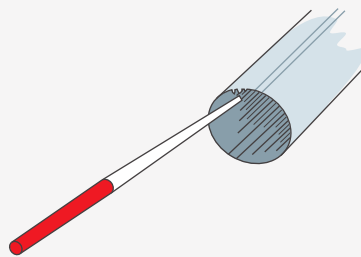

2. Deburr the edges and remove the metal residue.

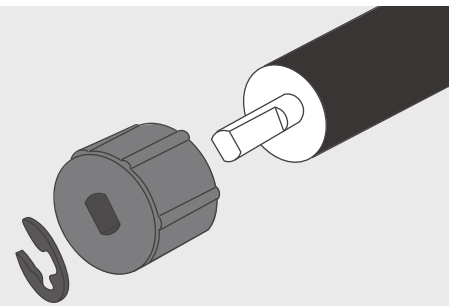

3. Place the adaptation on the motor.

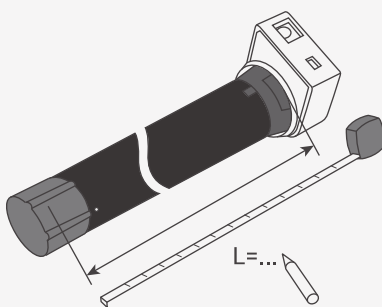

4. Measure the distance (L) between the inner edge of motors head and the end of the motors adaptor.

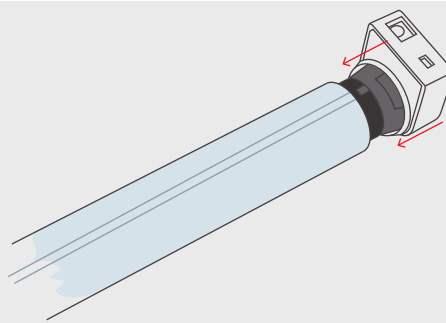

5. Insert the motor into the tube up to the point of connection between the edge of the tube and the inner edge of the motors head.

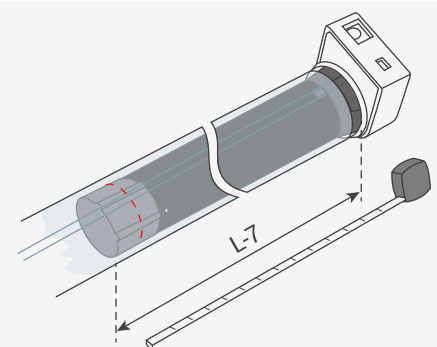

Attach the tube to the coupling part of the adaptation

4. Charging

1. It is recommended to charge the battery by min. 3 hours.
2. Ensure that the drive is fully charged before initial startup.
3. Charge the battery at least once every 6 months.
4. Use only power supply, dedicated to the device. Using another power supply may damage the motor.

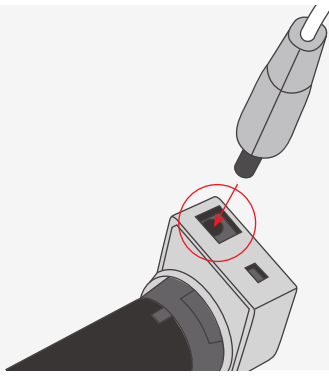

Connect the motor to the power supply.

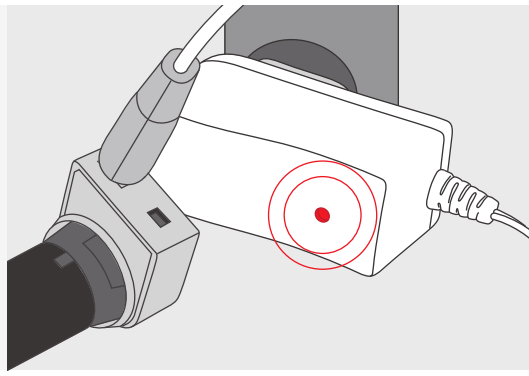

During charging, the LED diode on the power supply light is red.

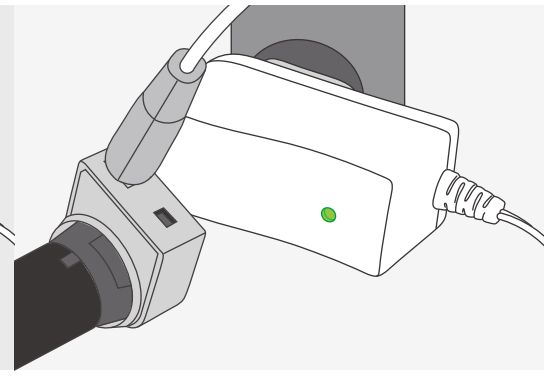

When the battery is fully charged, the LED diode will turn to green.

5. Range

Radio receiver range is a variable value and can differ from declared values depending on conditions in which device operates. Possible sources of changes in range are building construction, interference caused by other radio transmitters etc.

Blind with remotely controlled motor

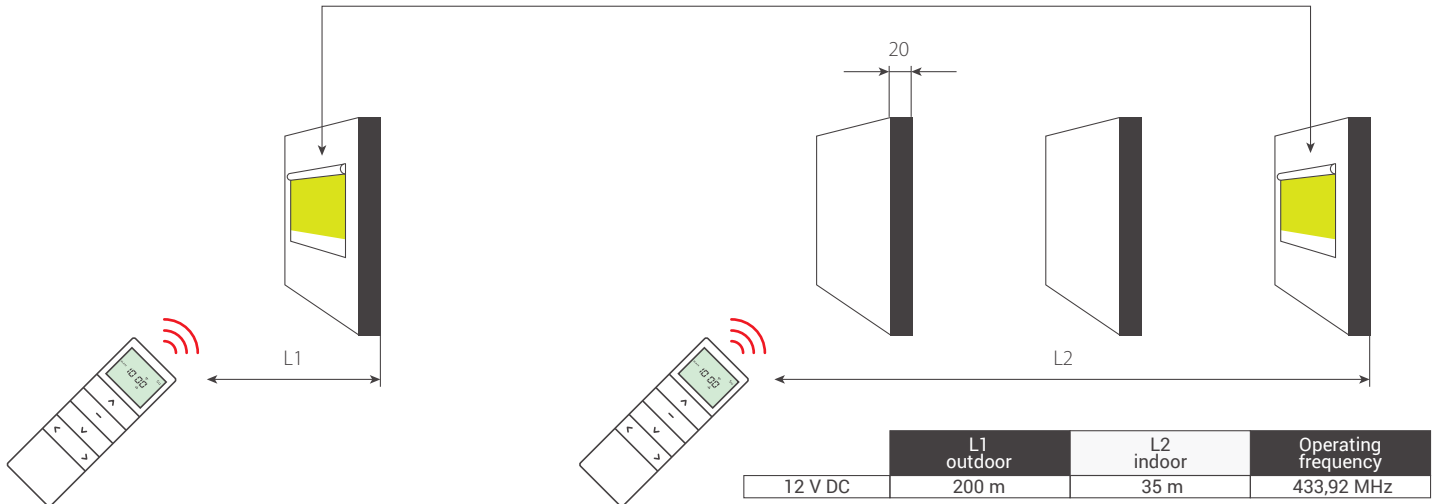

6. Programming first transmitter

Longer than 5 seconds pause between series of button clicks during programming will cause device to switch off from programming mode without saving any changes.

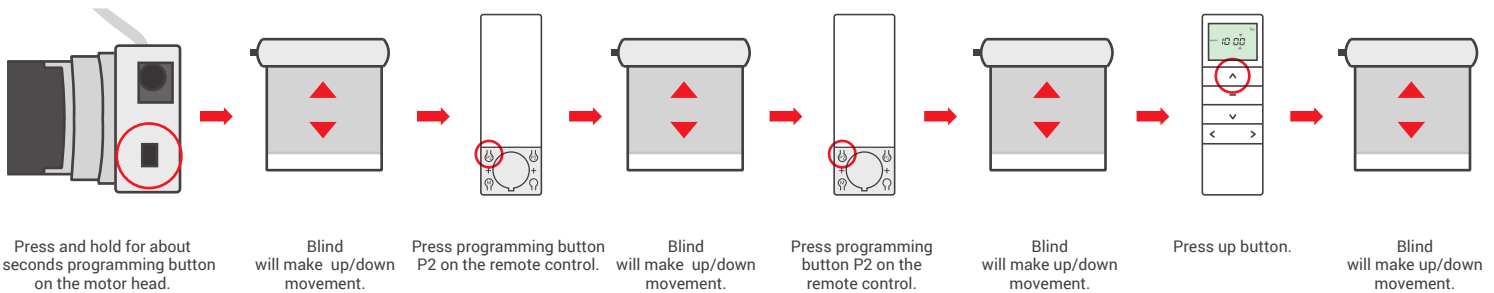

7. Changing motors direction

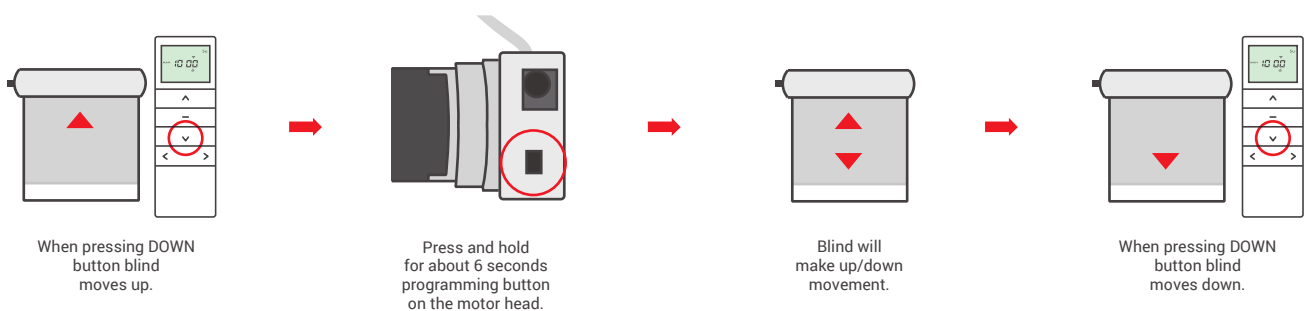

8. Programming limit positions

To set the upper and lower limit position press the programming button P2 during the motor movement, it causes the work displacement. Then you can precisely set the limit positions. Pressing the P2 button again motor will run continuously.

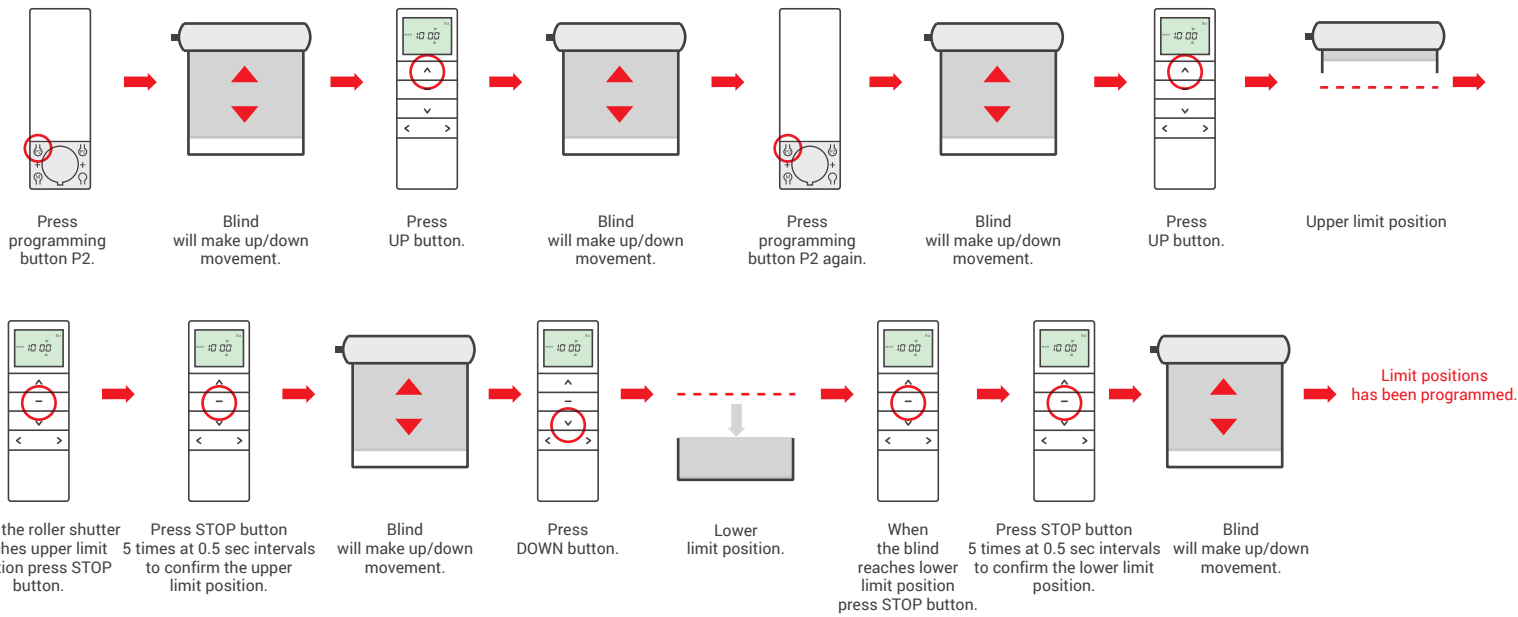

9. Removing limit positions

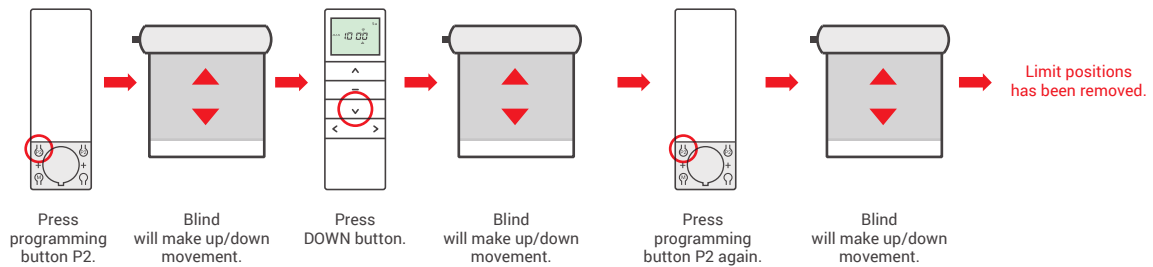

10. Programming the third limit position

- After setting the upper and lower limit positions, it is possible to set the third position (favorite) between those positions.
- Hold the STOP button for 3 seconds to set the blind in third limit position.
- When the motor is in pulse mode, hold the STOP button for 3 seconds, blind reaches lower limit position, and then to the set third position.

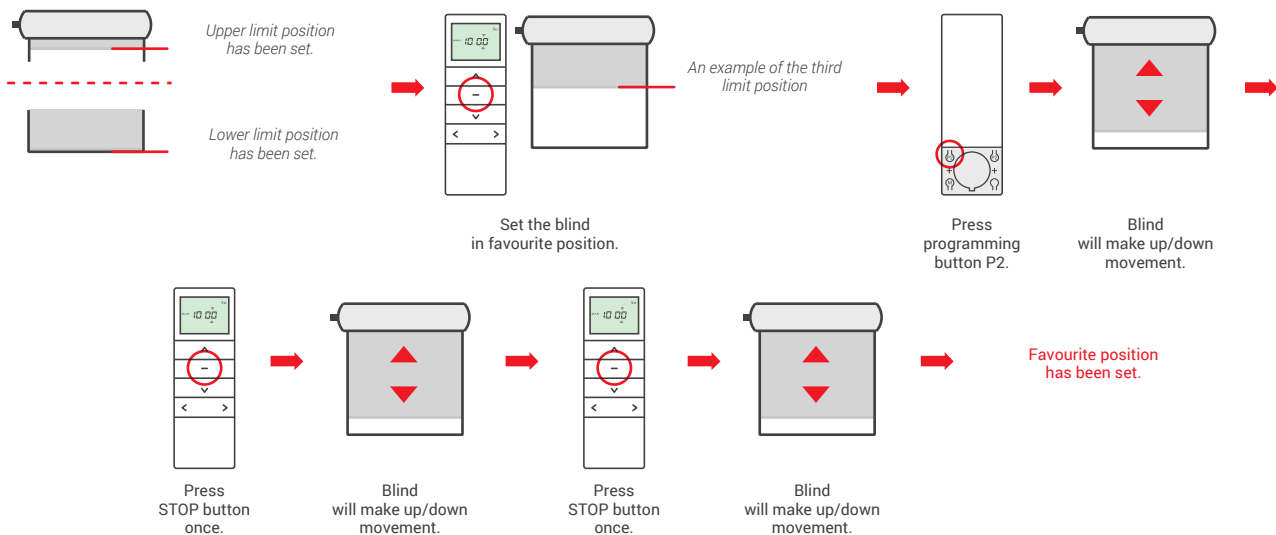

11. Removing third limit position

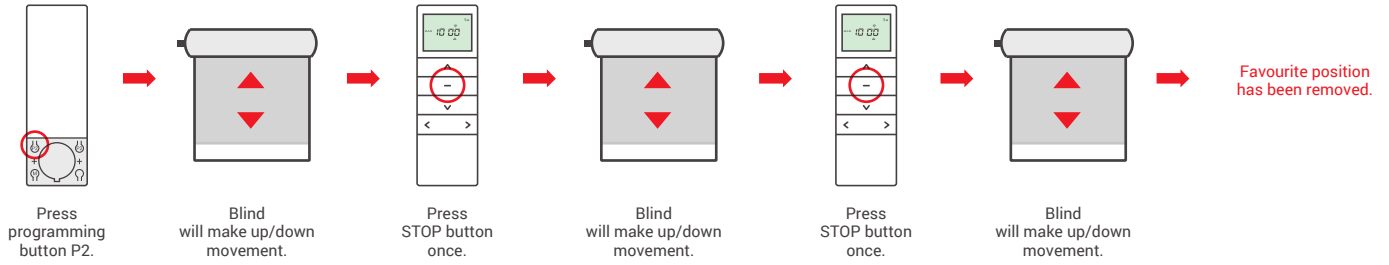

12. Programming another transmitter

Receiver can be controlled by up to 20 transmitters.

Longer than 5 seconds pause between series of button clicks during programming will cause device to switch off from programming mode without saving any changes.

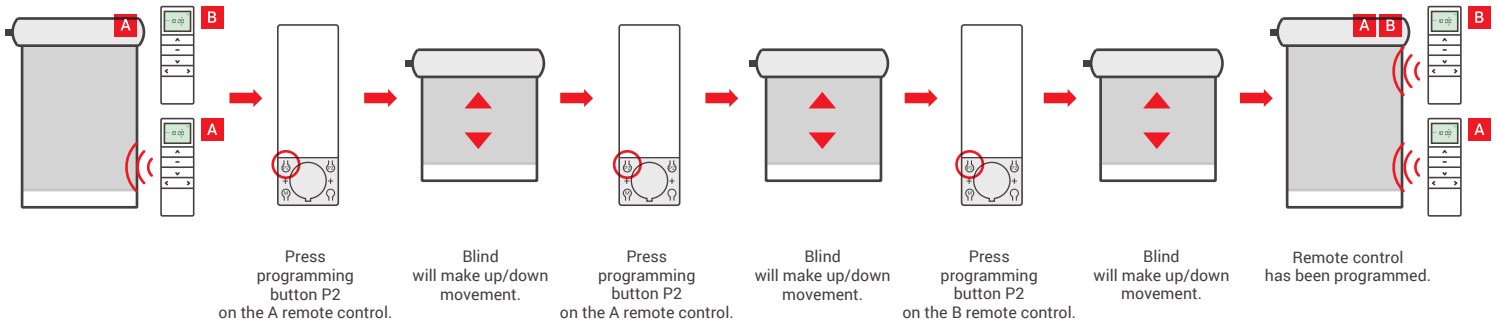

13. Deleting another transmitter

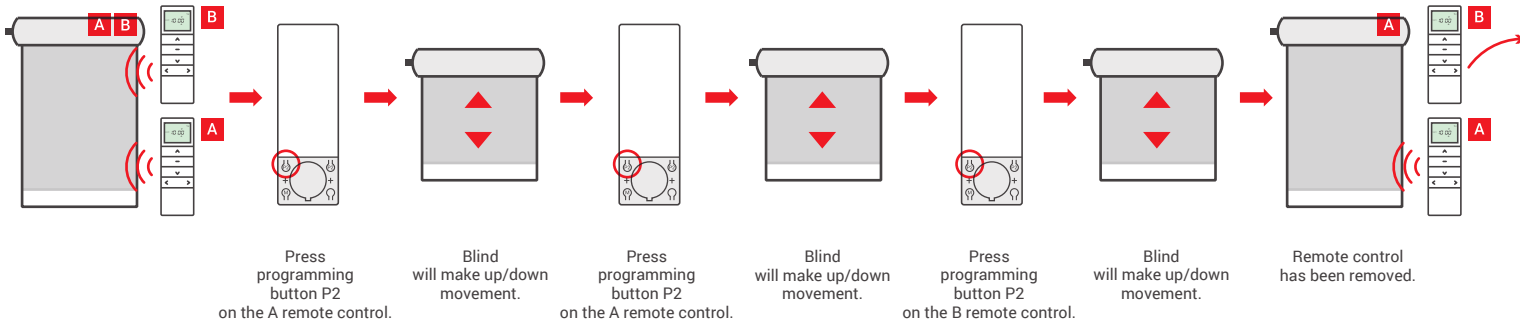

14. Deleting motor memory

Deleting memory of motors radio receiver will cause for all programmed transmitters to be lost.

Longer than 5 seconds pause between series of button clicks during programming will cause device to switch off from programming mode without saving any changes.

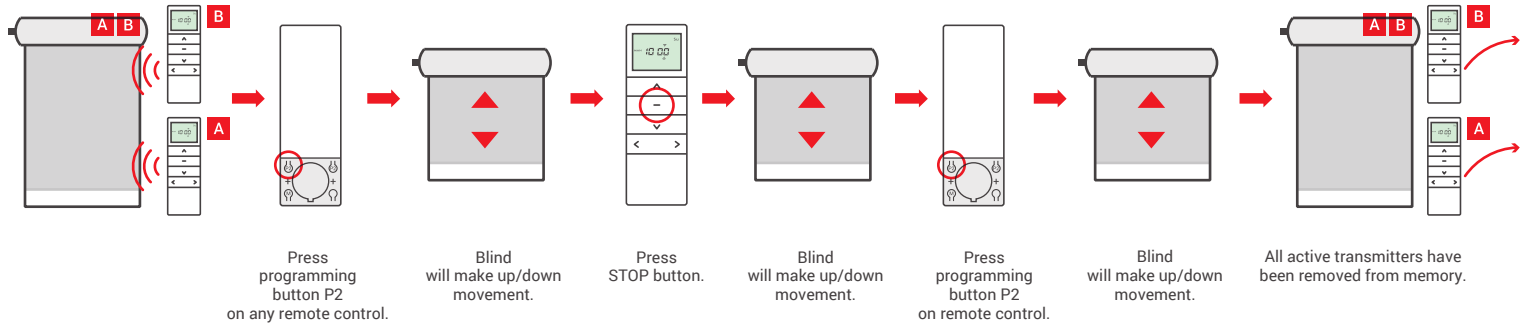

15. Activating impulse mode

Longer than 5 seconds pause between series of button clicks during programming will cause device to switch off from programming mode without saving any changes. To reverse this procedure please repeat the instruction

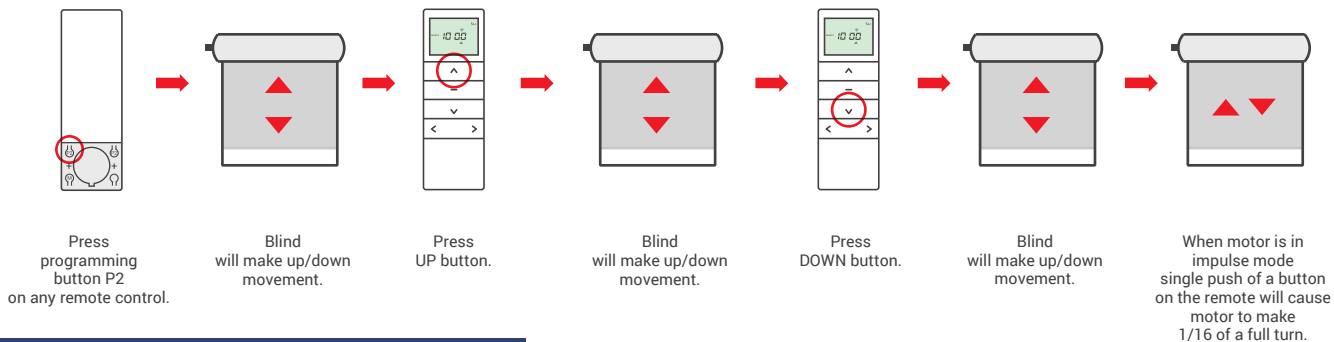

16. Programming key-ring remotes

When programming key-ring remotes that do not have additional P2 programming button the same function is substituted with simultaneous push of STOP and UP buttons.

Longer than 5 seconds pause between series of button clicks during programming will cause device to switch off from programming mode without saving any changes.

